

HPT-20/25/30 HAND PALLET TRUCK(2 TONS/2.5 TONS/3 TONS)

- LOAD CAPACITY 2000KG/2500KG/3000KG.
- HIGH QUALITY HYDRAULIC LIFTING CYLINDER IS DURABLE, RELIABLE.
- NO OIL LEAKAGE.
- EASY HANDLING.
- EASY LIFTING.
- BAKED ENAMEL COATING.
- WITH AN OVERLOAD RELIEF VALUE TO AVOID MISUSE DUE TO OVER LOADING.
- STEER AND FORK WHEELS ARE MADE BY STEEL AND COVERED BY POLYURETHANE.



There is no special operation training required. The spring-loaded loop handle provides easy operation and automatically returns to vertical position when released. Neutral allows the operator to handle load at the most convenient angle.

One piece "C"-channel formed steel reinforces fork strength to carry more load without bending. Incorporated with DUCTILE IRON castings at pivotal points, no grease fitting is required. Dual wheels sets are also available.

Every 6 units are packed on a wooden pallet for export.

Reliable, durable and critical hydraulic pump withstands thousands of lifting/ lowering cycles. And it is well sealed to prevent leaking.

Item	Standard	Option
Fork Height lowered(H1)	83 mm	76 mm
Fork Height lifted(H2)	203 mm	196 mm
Fork Wheels	ø78mmx94mm	ø78mmx70mm
No. of Fork Wheels	1pcx2	2pcsx2
Steer Wheels	ø180mmx50mm	ø180mmx50mm
Wheel Material	Steel Covered By Poly-urethane	Steel Covered By Nylon
Service Weight	95 kg	
Fork Thickness	45 mm	

Model	Overall Width(A)	Fork Length(L)	Inner Width(B)
HPT-NS	520 mm	910 mm	200 mm
HPT-NM	520 mm	1070 mm	200 mm
HPT-WM	685 mm	1070 mm	365 mm
HPT-WL	685 mm	1200 mm	365 mm

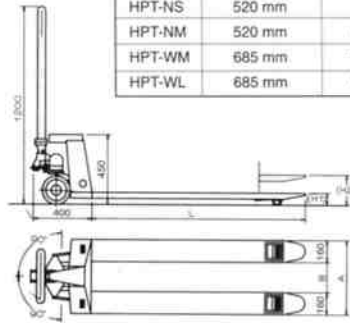

LT-150F/300F/350D/500/500D/800/1000 LIFT TABLE(150KG-1000KG)

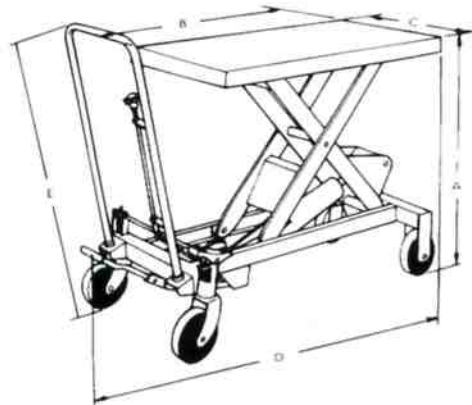

Model	LT-150F	LT-300F	LT-350D	LT-500	LT-500D	LT-800	LT-1000
LOAD CAPACITY(KG)	150	300	350	500	500	800	1000
A MAX.LIFTING HEIGHT(MM)	750	900	1300	960	1300	1000	1000
MIN.TABLE HEIGHT(MM)	250	320	350	325	350	410	410
B TABLE LENGTH(MM)	700	810	910	910	910	1000	1000
C TABLE WIDTH(MM)	450	500	520	520	520	513	513
D OVERALL LENGTH(MM)	875	1020	1098	1100	1098	1320	1320
E HANDLE HEIGHT(MM)	825	960	960	960	960	980	980
OVERALL WIDTH(MM)	450	500	520	520	520	575	575
WHEELS SIZE(MM)	100X32	127X38	127X38	127X38	127X38	150X40	150X40
NO. OF BRAKE	1	1	1	1	1	2	2
SERVICE WEIGHT(KG)	34	72	95	85	100	110	115

- NOTE. F:FOLDABLE HANDLE**
D:DOUBLE PANTOGRAPH
- 2 BRAKES ON 2 WHEELS IS STANDARD FOR LT-800/1000.
 - 2 BRAKES ON 2 WHEELS IS OPTIONAL FOR LT-150F~LT-500D.